

Boxer Pumps > Products > Liquid Diaphragm Pump

3MQ liquid diaphragm pump with DC Motor.



Technical Data

Free Flow	3.4 l/min
Max Pressure	2.0 bar
Max Vacuum	-500 mbar
Free Flow (gas / dry)	6.5 l/min
Max Suction Height (dry)	3.0 m H ₂ O
Voltage Options	12 / 24 V DC
Power Consumption	7.0 to 11.0 W
Terminal Resistance	6.5 Ω / 25.0 Ω (12 V / 24 V)
Wire Length	300 mm (7 mm stripped / tinned)
Wire Colours	Red (+V), Black (GND)
Wire Gauge	22 AWG
EMC Suppression	2 x L (2 x 3.9 μH)
Max. Motor Surface Temperature	80 °C
Motor Insulation Class	E
Recommended PWM Frequency	> 16 kHz
Max Ambient Operating Temperature	50 °C
Max Media Temperature	100 °C
Elastomer Options:	
Diaphragm	EPDM / Nitrile / Viton / Silicone
Valves	EPDM / Nitrile / Viton / Silicone
O-Rings	EPDM / Nitrile / Viton / Silicone
Eccentric Options:	0.8 / 1.0 mm
Other Wetted Parts	PPS (polyphenylene sulphide)
Mounting	Supplied with mounting bracket (see drawing, page 2)
Flow Control	→ PWM Flow Controller
Weight	545 g

Bold indicates configuration applicable to this datasheet

Flow Curve

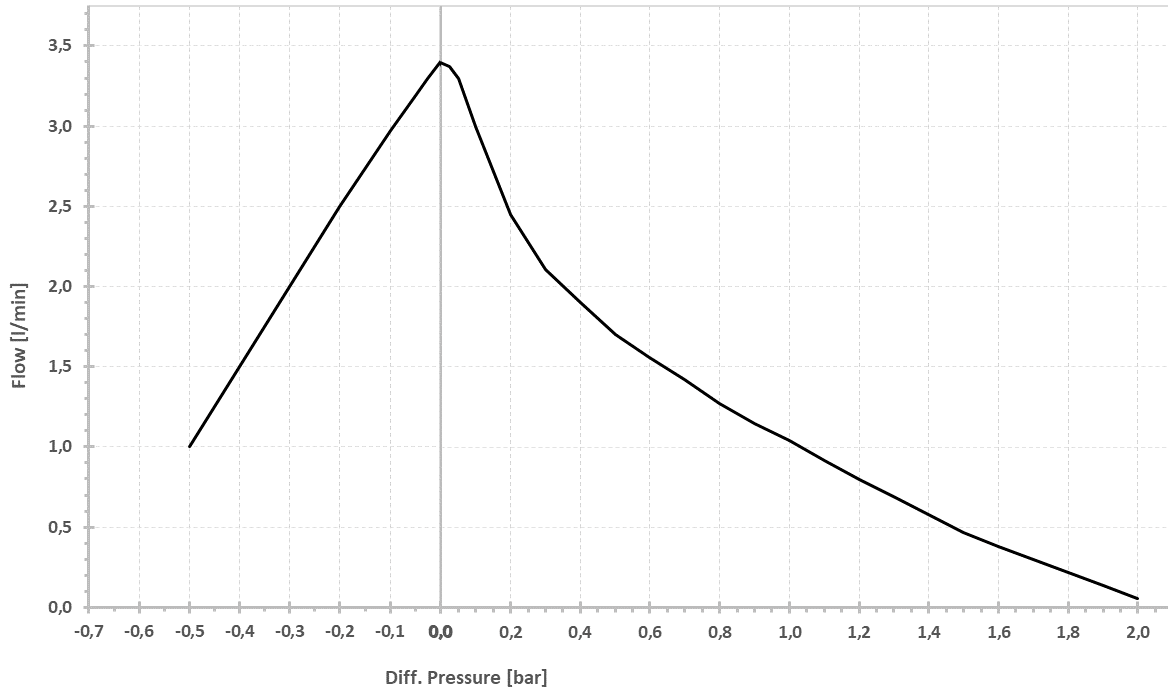

Drawing

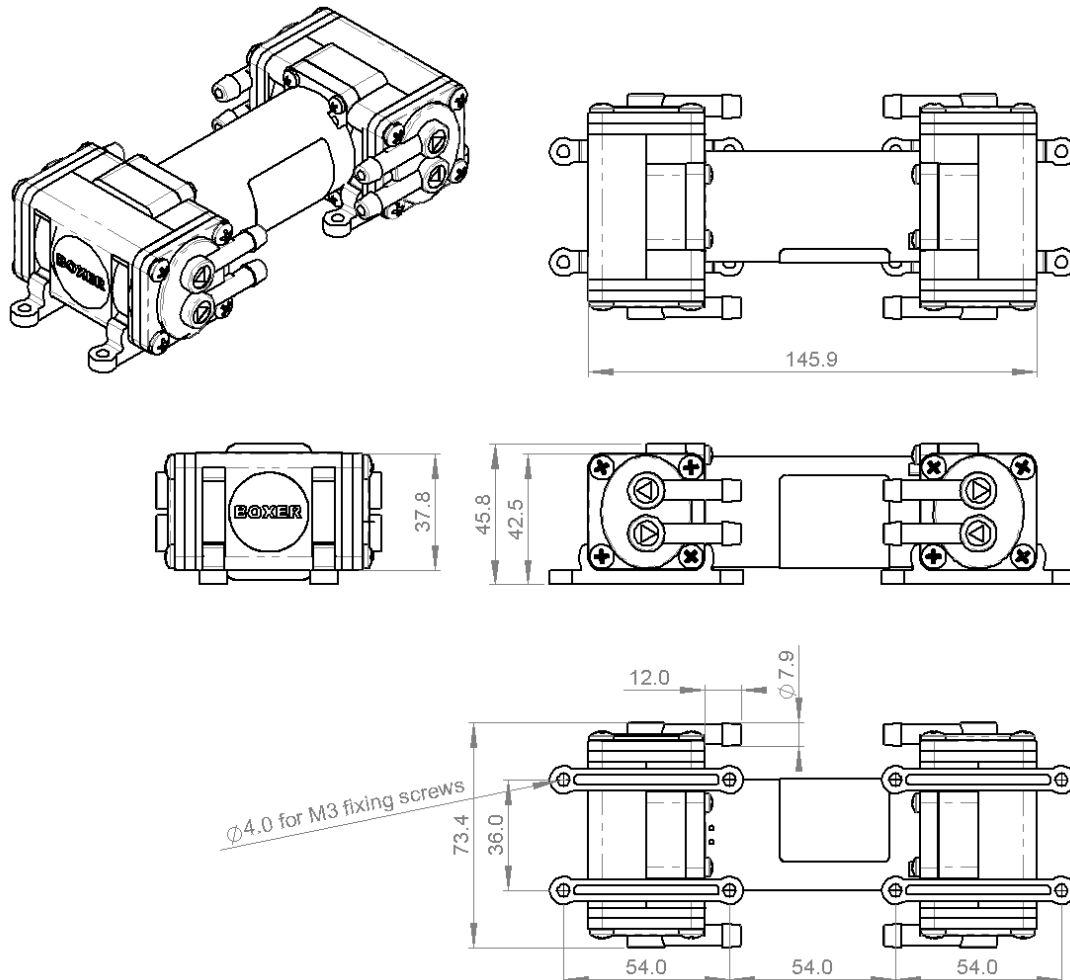

Links to Drawing and STEP file:

→ [Drawing \(.png\)](#)

→ [STEP \(.zip\)](#)

Boxer Pumps > Products > Liquid Diaphragm Pump

Order Information

Part Number	Description
3234.130	3MQ 12 V DC
3234.254	3MQ 24 V DC

Please enquire for part numbers of other configurations.

BOX-it (Webshop for online purchase)

Sample quantities are available for direct online purchase:



→ [BOX-it](#)

Additional Information (Links):

- [3MQ Webpage](#)
- [Boxer liquid diaphragm pump overview](#)

All data is representative for initial selection purposes. It is the responsibility of the user to determine suitability for the intended use. Technical changes reserved.